



LD141/WD141 SERIES BUTTERFLY VALVE

INSTALLATION OPERATION MAINTENANCE

TABLE OF CONTENTS

INTRODUCTION	3
DESIGN FEATURES.....	3
PRODUCT STORAGE.....	3
PRODUCT MARKING.....	3
FIGURE 1. APOLLO® BUTTERFLY VALVE I.D. TAG.....	3
OPERATING PRESSURES.....	4
FLANGE AND PIPE COMPATIBILITY.....	4
TABLE 1. BUTTERFLY VALVE DISC CHORD DIMENSIONS.....	4
INSTALLATION INFORMATION	5
INSTALLATION INSTRUCTIONS.....	5
FIGURE 2. VALVE IN PARTIALLY OPEN POSITION.....	5
FIGURE 3. VALVE IN FULL OPEN POSITION.....	6
TABLE 2. SEAT MATERIAL TEMPERATURE RATING.....	6
FIGURE 4. FLANGE BOLT TIGHTENING SEQUENCE AND TORQUE.....	6
TABLE 3. STUD AND BOLT SPECIFICATION FOR LUG AND WAFFER.....	7
MAINTENANCE AND REPAIR.....	8
ASSEMBLY/DISASSEMBLY INSTRUCTIONS	8
LEVER HANDLE MOUNTING PROCEDURE.....	8
FIGURE 5. NOTCHPLATE INSTALLATION POSITION.....	9
GEAR OPERATOR MOUNTING/SETTING PROCEDURE.....	9
ILLUSTRATIONS 1 & 2. SETTING GEAR OPERATOR.....	10
MEMORY STOP ASSEMBLY PROCEDURE FOR INFINITE POSITION HANDLES.....	10
FIGURE 6. MEMORY STOP ASSEMBLY FOR INFINITE POSITION HANDLES.....	10
BUTTERFLY VALVE PARTS LIST AND DRAWING	11
FIGURE 6. LD141/WD141 PARTS LIST & ASSEMBLY DRAWING.....	10
FIGURE 7. EXAMPLE NAME PLATE.....	11
FIGURE 8. APPROXIMATE WEIGHTS.....	12
FIGURE 9. 2" – 14" LD141 DRAWING.....	13
FIGURE 10. 16" – 24" LD141 DRAWING.....	14
FIGURE 12. 28" – 48" LD141 DRAWING.....	15
FIGURE 11. 2" – 14" WD141 DRAWING.....	16
FIGURE 12. 16" – 24" WD141 DRAWING.....	17
AMENDMENT REGISTER	18

INTRODUCTION

DESIGN FEATURES FOR LD141/WD141 SERIES

- Available in wafer or lug body.
- Flange holes comply with ANSI Class 125/150 dimensions.
- Large Diameter (28"-48") flanges comply with ASME B16.47 Class 150 Series A.
- Cast in top plate with ISO-5211 mounting dimensions provides for direct mounting of Apollo® actuators and manual operators.
- The face-to-face dimensions were designed to comply with MSS SP-67 and API 609.
- Wafer body features four alignment holes for ease of installation.
- Through-shaft design with spline connection between the stem and disc. Disc-to-seat interface provides bubble-tight shut off with reduced torque and extended service life.
- Equipped with a stretch-resistant, non-collapsible, blowout-proof, phenolic-backed cartridge seat. (14" through 24" have aluminum backing)
- Meets the intent and has passed AWWA C504-87 Section 5 proof of design tests.
- Factory tested to 110% of full rated pressure in both directions before shipping.
- NSF 372 Approved. Note black Viton B seat not included in approval.
- NSF 61 Approved for 2"-12" Aluminum Bronze/SS disc with EPDM/Buna-N Seats

PRODUCT STORAGE

- The valves should be stored with the disc in the partially open position.
- The valves should be stored indoors in a clean, dry, well-ventilated place away from corrosive materials and protected from excessive dust and dirt.
- The valves should be stored on a rack or pallet off the floor and arranged to prevent damage during handling.
- Keeps valves out of direct sunlight and in a cool location to prolong elastomer life.
- Valves should be protected to prevent damage to the flange faces, disc sealing edge and operator.

PRODUCT MARKING

All APOLLO® Butterfly Valves are equipped with an identification tag attached to the valve neck (Figure 1). This tag provides the model number, part number, size, max pressure rating, and date of manufacture.

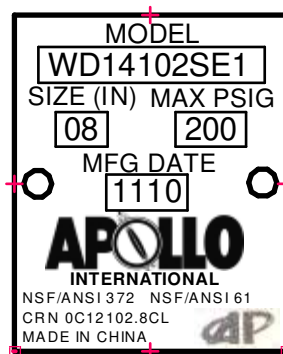

FIGURE 1. APOLLO® BUTTERFLY VALVE IDENTIFICATION TAG EXAMPLE

OPERATING PRESSURES FOR LD141/WD141 SERIES

- 2"-12" (50mm-300mm) – 200 psig (13.78 bar)
- 14"-24" (350mm-600mm) – 150 psig (10.34bar)

FLANGE AND PIPE COMPATIBILITY

APOLLO® Butterfly Valves are designed to fit between the following piping flanges:

- ANSI 125 Cast iron flanges. (all sizes)
- ANSI 150 Steel Flanges, schedule 40. (all sizes)
- ANSI 150 Steel Flanges, schedule 80. (2"-12" remove 1/16" raised face.)

NOTE: When installing valve in schedule 80 piping, make sure the valve is properly centered between the pipe flanges to prevent disc edge damage since the clearance between the disc O.D. and the pipe I.D. is reduced. If there is a compatibility question, compare the minimum pipe I.D. with the disc chord dimensions in Table 1.

Valve	Size	Disc Chord
(in)	(mm)	
2	50	1.133
2.5	65	1.706
3	80	2.450
4	100	3.488
5	125	4.296
6	150	5.697
8	200	7.468
10	250	9.484
12	300	11.456
14	350	13.000
16	400	14.970
18	450	16.847
20	500	18.650
24	600	22.558

TABLE 1. BUTTERFLY VALVE DISC CHORD DIMENSIONS

INSTALLATION INFORMATION

APOLLO® butterfly valves are designed for use between the faces of ANSI 125 and 150 pound flat, raised face, slip-on or weld-neck flanges at the pressure indicated on the nameplate. **Flange gaskets should not be used.** Consideration should be given to the proper piping alignment prior to the installation of any iron lug bodied valve. All APOLLO® resilient seated butterfly valves are bi-directional with the ability to control flow equally in either direction. All LD141 Series APOLLO® lug style butterfly valves up to 12" may be used for dead-end service in either direction at their full pressure rating.

INSTALLATION INSTRUCTIONS

1. Check to make sure that the pipe flange and valve sealing faces are clean and free from any debris (pipe scale, weld slag, etc.).
2. Check the valve nameplate to ensure that the pressure and valve materials are correct for the application. See Table 2 for seat material temperature ratings.

Warning! – APOLLO® Butterfly valves should never be installed where service conditions could exceed the valve ratings. Failure to heed warning may result in personal injury and/or property damage.

3. The seat sealing face on the LD141/WD141 Series butterfly valves is wider than the valve body providing a leak-proof seal when compressed between pipe flanges. Therefore, no flange gaskets are required when installing any APOLLO® butterfly valve.
4. To prevent damage to the disc sealing edge during installation, position the disc in the "partially open" position (Figure 2) so that the disc is still contained within the valve body.

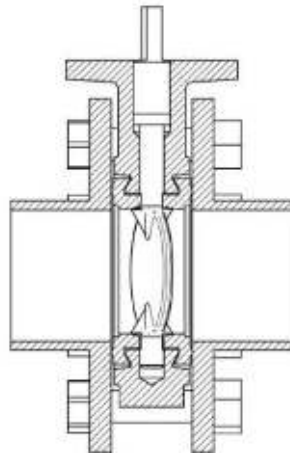

FIGURE 2. VALVE IN THE PARTIALLY OPEN POSITION

5. Spread the pipe flanges apart allowing the valve to be slipped easily in between the flanges.
6. Center the valve between the flanges and loosely install all the flange bolts. On the WD141 wafer valve, the flange bolts that pass through the alignment lugs should be installed first. Consult Table 3 for correct flange bolt size and quantity.

- Slowly move the valve to the "full open" position (Figure 3) and back to the partially open position ensuring that the disc moves freely without any obstruction. If no obstruction is encountered, return the valve to the full open position and hand tighten all flange bolts using the bolt tightening sequence shown in Figure 4.

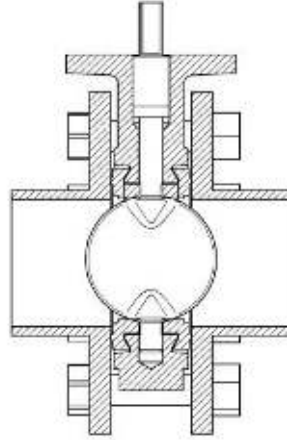

FIGURE 3. VALVE IN THE FULL OPEN POSITION

- Rotate the disc from the full open position to the full closed position and make sure that the valve is properly centered and the disc edge does not contact the pipe I.D. Return the disc to the full open position and tighten the flange bolts incrementally following the bolt tightening sequence and suggested torque values provided in Figure 4. After all flange bolts are fully tightened, cycle the valve from full open to full closed to ensure there is proper disc clearance.

Type	Min	Max
Buna-N	+10 °F (-12 °C)	+180 °F (82 °C)
EPDM	-30 °F (-34 °C)	+225 °F (135 °C)
Viton	-20 °F (-29 °C)	+300 °F (149 °C)

TABLE 2. SEAT MATERIAL TEMPERATURE RATING

FLANGE SIZE	BOLT SIZE	MIN BOLT TORQUE	MAX BOLT TORQUE	
(in)	(in)	(Ft/LBS)	(Ft/LBS)	
2"-4"	5/8"	20	70	
5"-8"	3/4"	30	120	
10"-12"	7/8"	50	200	
14"-16"	1"	70	240	
18"-20"	1-1/8"	100	380	
24"	1-1/4"	140	520	

FIGURE 4. FLANGE BOLT TIGHTENING SEQUENCE AND TORQUE VALUES

WAFER BODY HEAVY HEX BOLTS & NUTS WITH NC THREAD					LUG BODY REGULAR HEX HEAD SCREWS WITH NC THREADS		
Valve Size	Diameter	Length	Quantity		Diameter	Length	Quantity
(in)	(mm)	(in)	(in)		(in)	(in)	
2	50	5/8"	4-1/2"	4	5/8"	1-1/2"	8
2.5	65	5/8"	4-1/2"	4	5/8"	1-1/2"	8
3	80	5/8"	5"	4	5/8"	1-3/4"	8
4	100	5/8"	5"	8	5/8"	1-3/4"	16
5	125	3/4"	5-1/2"	8	3/4"	1-3/4"	16
6	150	3/4"	5-1/2"	8	3/4"	2"	16
8	200	3/4"	6"	8	3/4"	2-1/4"	16
10	250	7/8"	6-1/2"	12	7/8"	2-1/4"	24
12	300	7/8"	7"	12	7/8"	2-1/2"	24
14	350	1"	7-1/2"	12	1"	2-3/4"	24
16	400	1"	8-1/2"	16	1"	3"	32
18	450	1-1/8"	9-1/2"	16	1-1/8"	3-1/2"	32
20	500	1-1/8"	11"	20	1-1/8"	4"	40
24	600	1-1/4"	12"	20	1-1/4"	4-1/2"	40

LARGE DIAMETER LUG VALVE HEX HEAD SCREWS WITH NC THREADS					LARGE DIAMETER LUG VALVE BLIND HEX HEAD SCREWS WITH NC THREADS		
Valve Size	Diameter	Length	Quantity		Diameter	Length	Quantity
(in)	(mm)	(in)	(in)		(in)	(in)	
28	700	1-1/4"	5"	48	1-1/4"	3-1/2"	8
30	750	1-1/4"	5-1/2"	48	1-1/4"	3-1/2"	8
32	800	1-1/2"	6"	48	1-1/2"	4-1/2"	8
36	900	1-1/2"	6-1/2"	56	1-1/2"	4-1/2"	8
40	1000	1-1/2"	6-1/2"	64	1-1/2"	4-1/2"	8
42	1050	1-1/2"	7"	64	1-1/2"	5"	8
48	1200	1-1/2"	8"	80	1-1/2"	5-1/2"	8

Note: Large diameter valve flanges (28"-48") are ASME B16.47 Class 150 Series A.

TABLE 3. STUD AND BOLT SPECIFICATIONS FOR LD141/WD141

MAINTENANCE AND REPAIR

APOLLO® butterfly valves are designed for extended service with minimal wear and servicing. No regular lubrication is required. Prior to any repair or replacement, the valve must be removed from the line following these precautions:

1. The pipeline on either side of the valve must be depressurized and drained.
2. Ensure that the disc is in the partially open or full closed position before removing the valve from the line
3. **DO NOT** remove an actuator or operator from the valve while the line is still pressurized.

ASSEMBLY/DISASSEMBLY INSTRUCTIONS

The LD141/WD141 Series butterfly valves have field replaceable parts. However, assembly and disassembly in the field is not recommended due to the level of difficulty involved in disassembling and assembling the valve. Once the valve is removed from the line, inspect the parts for wear. If the valve parts show wear, replacement is necessary. Contact your local APOLLO® distributor for a replacement part or valve.

LEVER HANDLE MOUNTING PROCEDURE

1. Start by loosely assembling the notch plate on the valve top plate. The notch plate should be installed with the notches in the third quadrant of the valve top plate with the stop tabs at the 6 o'clock and 9 o'clock position. The notch plate should be installed with the stop tabs pointing upwards (Figure 5).
2. Next, install the handle so that the lever fully engages in the notches when the lever is released and tighten the notch plate screws
3. Compress the handle lever and position the disc so that the valve is in the full closed position. Align the last notch on the notch plate at the 9 o'clock position with the handle lever and tighten the notch plate screws.
4. Compress the handle lever and position the disc so that the valve is in the full open position and release the lever. The lever should line-up with the last notch on the notch plate at the 6 o'clock position.
5. Note:Notch plate can be rotated 90° degrees to accommodate user preference in regards to handle direction.

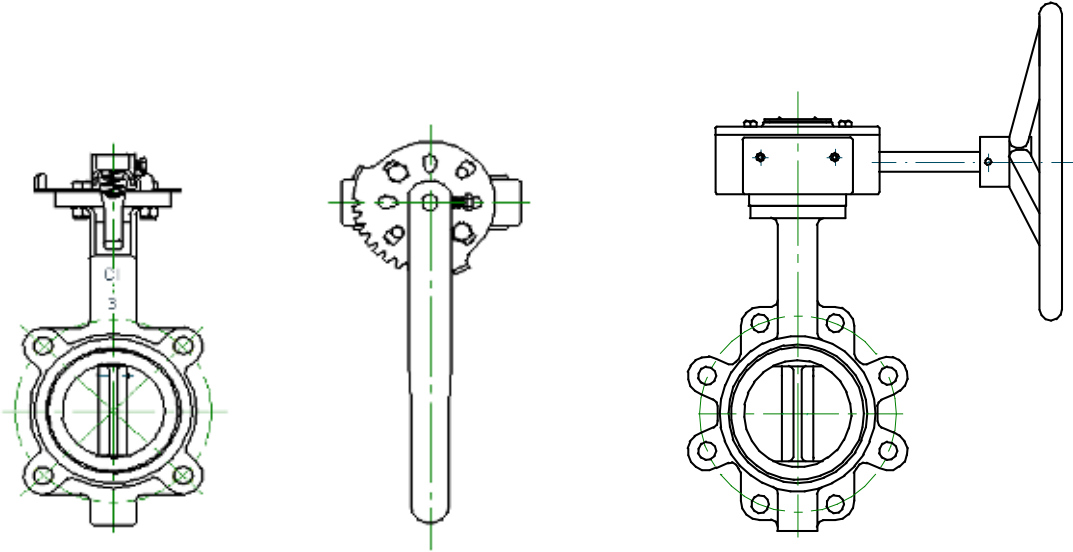
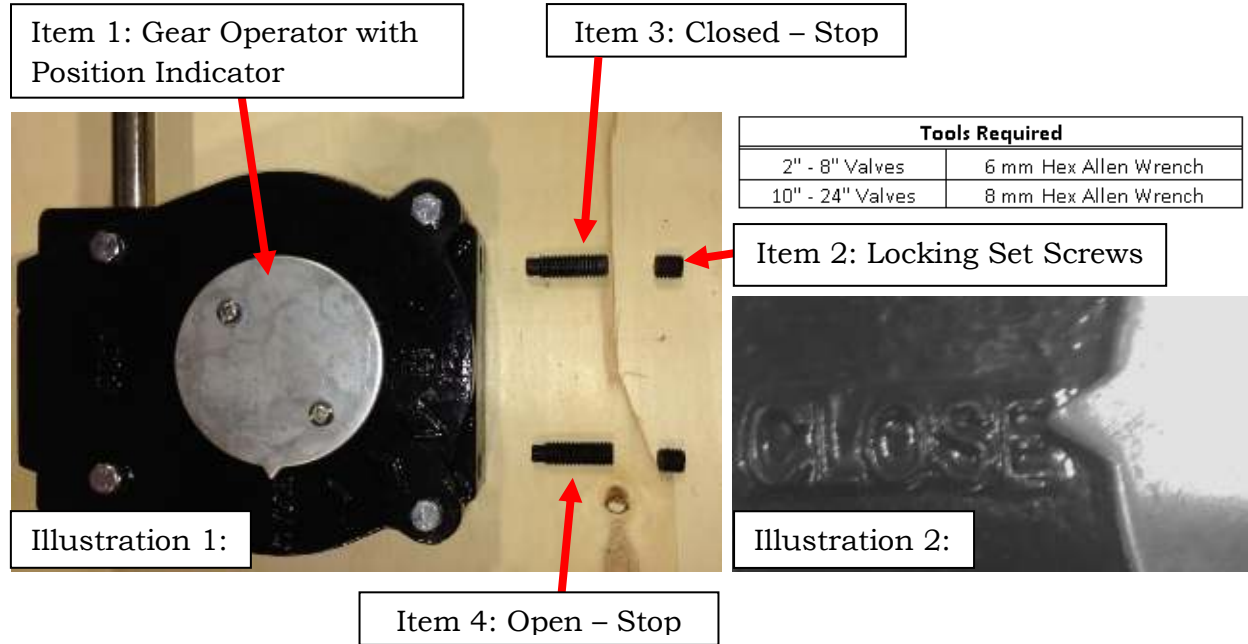

FIGURE 5. NOTCHPLATE AND GEAR OPERATOR INSTALLATION POSITION

GEAR OPERATOR MOUNTING/SETTING PROCEDURE

(Refer to Illustrations 1 & 2)

1. Mount gear operator (Item 1) on top of butterfly valve with four bolts and washers provided with each assembly.
2. Use Allen wrench to remove locking set screws (Item 2) from both sides of the gear operator.
3. Loosen the stop screws (Item 3 & 4) approximately three to four turns on both sides of the gear operator.
4. Rotate hand wheel to the full open position and tighten the "open" stop pin (Item 4). Now add locking set screw (Item 2) and lock "open" stop pin into place.
5. Rotate hand wheel to the full closed position and tighten the "Closed" stop pin (Item 3). Note disc should be centered in the seating surface.
6. Open disc to 20% then back to closed position. Re-adjust stop screw (Item 3) if necessary. Add locking set screw (Item 2) and lock "Closed" stop pin into place. You have now properly adjusted both the "Open" and "Closed" stop positions.
7. As a quick reference, note the position of the pointer and the word "CLOSE". The pointer should be near the center of close to the top of letter "E" in the word "CLOSE". See Illustration 2 for reference.



ILLUSTRATIONS 1 & 2: SETTING GEAR OPERATOR

MEMORY STOP ASSEMBLY PROCEDURE FOR INFINITE POSITION HANDLES

1. Using the bolt, washers, and wing-nut included in the infinite position handle kit, loosely assemble the parts to the infinite position plate using Figure 6 as a reference.
2. Slide the memory stop along the plate slide hole to the desired position and then tighten the bolt and wing-nut so that the memory stop will not be able to move freely.
3. Place the locking plate on the valve shaft followed by the valve handle and tighten the handle to the shaft. By turning the handle, the locking plate should adjust from the open/closed position to the position of the memory stop.

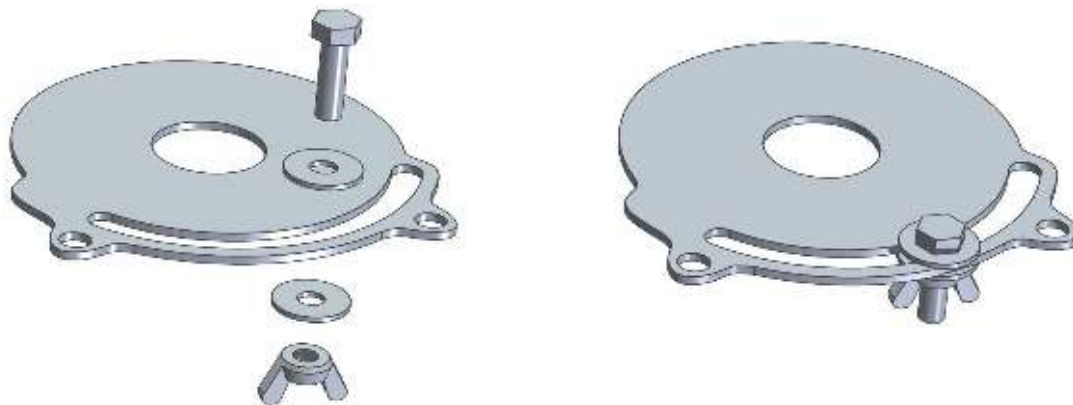

FIGURE 6. MEMORY STOP ASSEMBLY FOR INFINITE POSITION HANDLES

BUTTERFLY VALVE PART LIST AND DRAWINGS

Replacement parts are offered for the LD141/WD141 Series butterfly valve. Use parts list and assembly drawing in Figure 7 as reference when ordering replacement parts.

ITEM #	QTY	DESCRIPTION
1	1	BODY
2	1	SHAFT
3	1	SEAT
4	1	DISC
5	3	BUSHING
6	1	O-RING
7	1	WASHER
8	1	EXTERNAL RETENTION RING
9	1	INTERNAL RETENTION RING
10	2	SET SCREW, FLAT POINT
11	2	SET SCREW, CONE POINT
12	1	NAMEPLATE

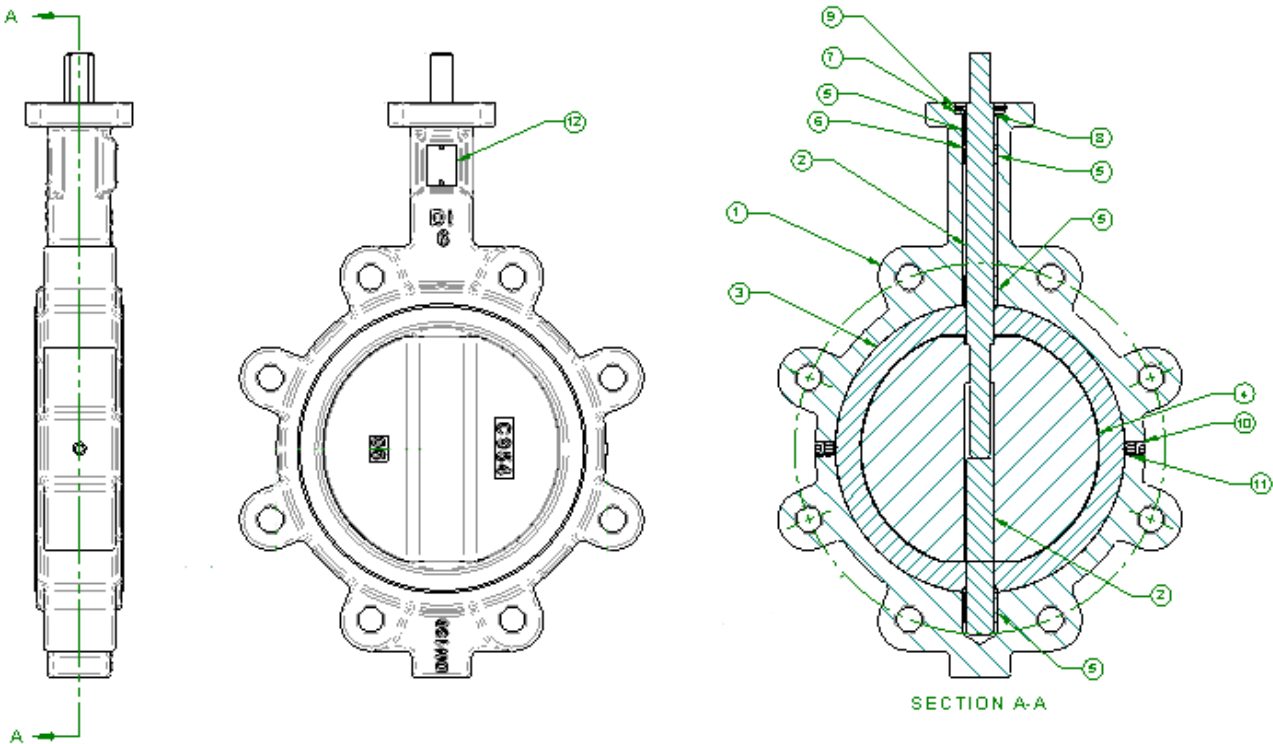

FIGURE 7. LD141/WD141 PARTS LIST & ASSEMBLY DRAWING

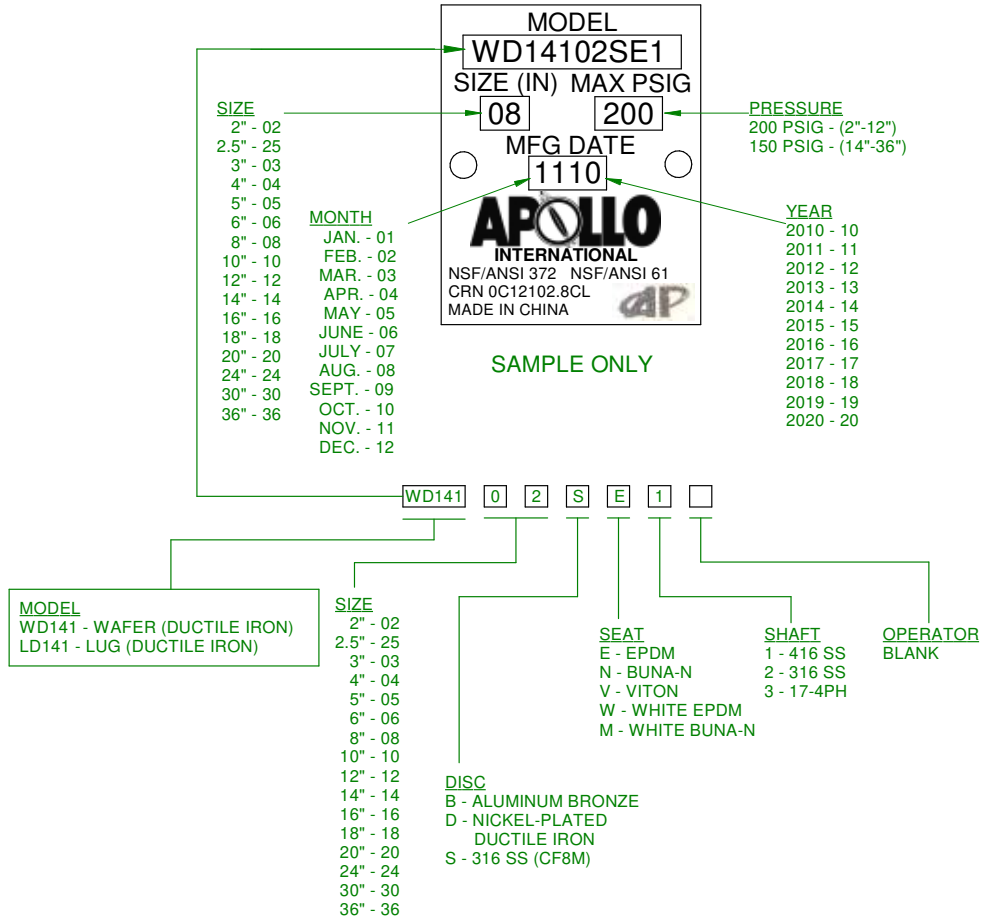

FIGURE 8. EXAMPLE NAME PLATE

VALVE SIZE		WD MODEL	LD MODEL
(IN)	(MM)	LBS (KG)	LBS (KG)
2	50	6 (2.7)	8 (3.6)
2.5	65	6 (2.7)	10 (4.5)
3	80	7 (3.2)	11 (5.0)
4	100	11 (5.0)	17 (7.7)
5	125	13 (5.9)	20 (9.1)
6	150	16 (7.3)	23 (10.4)
8	200	29 (13.2)	39 (17.7)
10	250	44 (20.0)	62 (28.1)
12	300	70 (31.8)	97 (44.0)
14*	350		148 (67.1)
16*	400		206 (93.4)
18*	450		277 (125.6)
20*	500		410 (186.0)
24*	600		592 (268.5)

*LD141 Series only

FIGURE 9. APPROXIMATE WEIGHTS

(DN)	(MM)	A	B	C	D	E	ØF	ØG	ØG2	KEY	ØH	ØH2	L	ØJ	ØK	N (MD141)	ØM
2	50	3.2	6.375	1.25	1.75	0.394	0.486	0.375	--	--	3.756	--	2.699	4.00	3.09	5/8"-11 (4X)	4.75
2.5	65	3.5	6.880	1.25	1.88	0.394	0.486	0.375	--	--	3.756	--	2.699	4.75	3.54	5/8"-11 (4X)	5.50
3	80	3.7	7.130	1.25	1.88	0.394	0.486	0.375	--	--	3.756	--	2.699	5.13	3.09	5/8"-11 (4X)	6.00
4	100	4.5	7.880	1.25	2.13	0.472	0.631	0.375	--	--	3.756	--	2.699	6.75	4.09	5/8"-11 (5X)	7.50
5	125	5.0	8.380	1.25	2.25	0.551	0.745	0.375	--	--	3.756	--	2.699	7.75	4.85	5/8"-10 (5X)	8.50
6	150	5.5	8.880	1.25	2.25	0.551	0.745	0.375	--	--	3.756	--	2.699	8.63	6.13	5/8"-10 (5X)	9.50
8	200	6.9	10.250	1.75	2.50	0.669	0.870	0.555	0.438	--	4.921	4.015	4.606	10.56	7.89	5/8"-10 (5X)	11.75
10	150	8.3	11.500	1.88	2.75	0.666	1.120	0.555	0.438	--	4.921	4.015	4.606	13.06	9.69	7/8"-9 (12X)	14.25
12	200	9.8	13.250	1.88	3.13	0.945	1.244	0.555	--	--	4.921	--	4.606	16.00	11.99	7/8"-9 (12X)	17.00
14	250	11.0	14.500	1.88	3.13	0.945	1.244	0.555	--	--	4.921	--	Ø5.91*	17.13	13.35	1"-8 (12X)	18.75

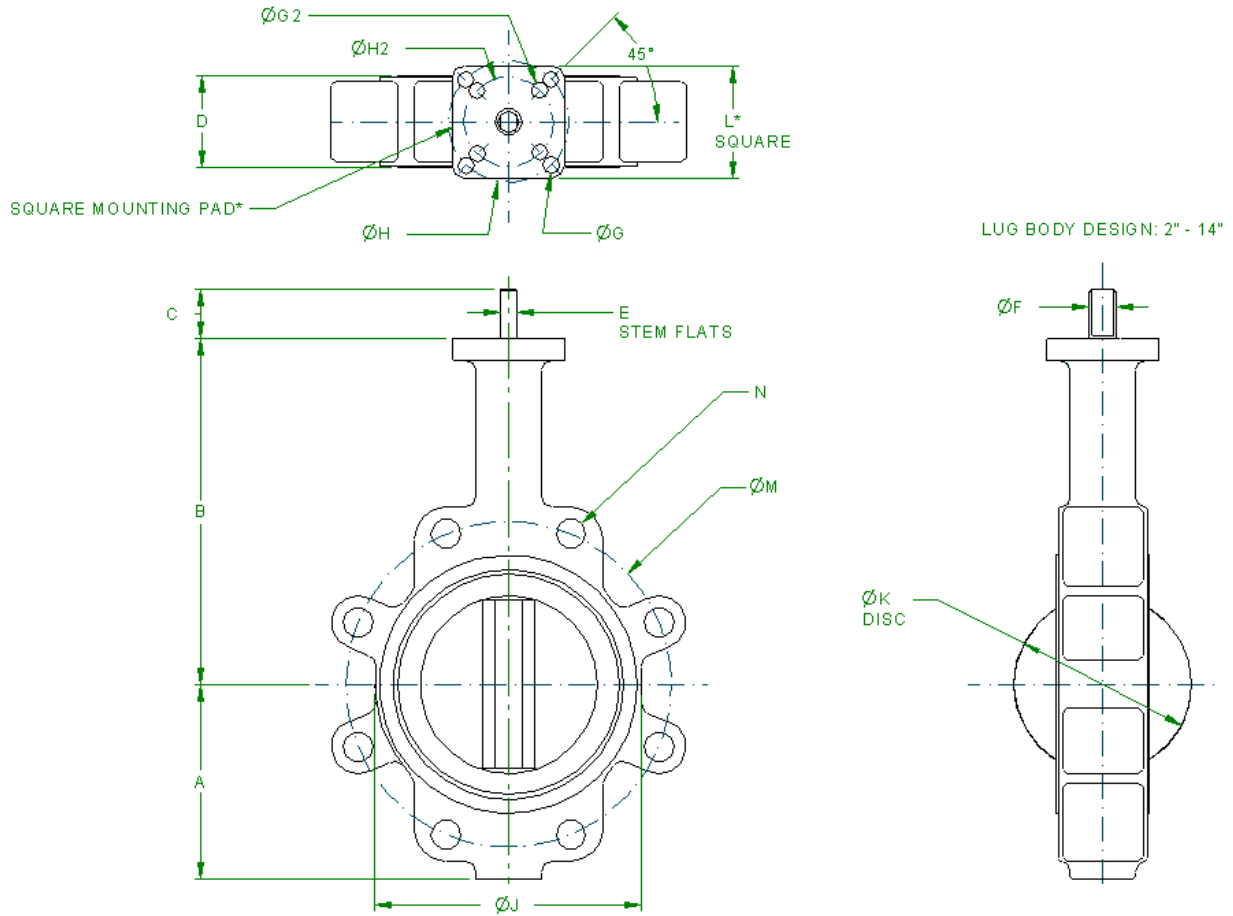

FIGURE 10. 2"- 14" LD141 DRAWING

(IN)	(MM)	A	B	C	D	ØF	ØG	KEY (SQUARE)	ØH	L	J	K	N (LD141)	M
16	400	12.0	15.750	2.00	3.50	1.813	0.563	0.313	4.921	Ø5.91	20.00	15.38	1"-8 (16 X)	21.25
18	450	13.2	16.630	2.00	4.25	1.500	0.813	0.375	6.496	Ø8.27	21.38	17.38	1 1/8"-8 (16 X)	22.75
20	500	14.7	18.880	2.50	5.25	1.625	0.813	0.375	6.496	Ø8.27	23.31	19.38	1 1/8"-8 (20 X)	25.00
24	600	18.1	22.130	2.75	6.13	2.000	0.813	0.500	6.496	Ø8.27	27.88	23.38	1 1/4"-8 (20 X)	29.50

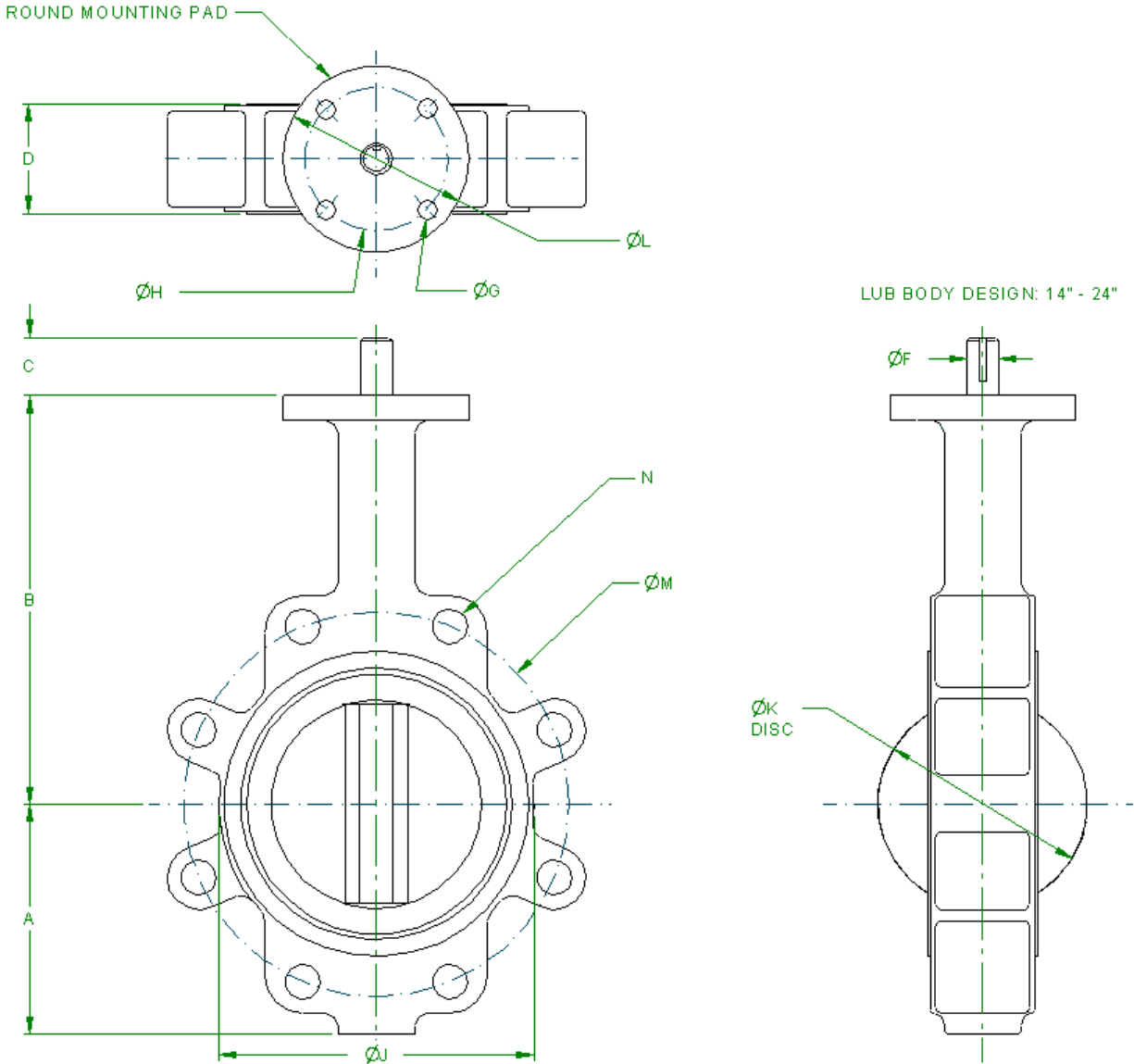

FIGURE 11. 16"- 24" LD141 DRAWING

Size (in)	Size (mm)	A	B	C	D	ØD1	ØD2	ØD3	ØD4	ØD5	ØD6	N-UNC	Ød1
28	700	45.83	24.57	6.02	6.50	27.36	33.99	7.87	10.00	11.81	2.49	1 1/4" (x28)	5/16" (x8)
30	750	45.51	25.47	6.02	6.61	29.25	36.00	7.87	10.00	11.81	2.49	1 1/4" (x28)	5/16" (x8)
32	800	50.51	26.46	6.02	7.48	31.27	38.50	7.87	10.00	11.81	2.49	1 1/2" (x32)	5/16" (x8)
36	900	51.89	26.89	6.77	7.99	34.03	42.75	7.87	10.00	11.81	2.95	1 1/2" (x32)	5/16" (x8)
40	1000	60.63	31.50	6.77	8.50	37.99	47.24	7.87	10.00	11.81	3.35	1 1/2" (x36)	5/16" (x8)
42	1050	65.16	33.78	6.77	9.88	40.53	49.50	7.87	10.00	11.81	3.74	1 1/2" (x36)	5/16" (x8)
48	1200	71.85	37.72	7.44	10.87	45.67	56.00	9.06	11.73	13.78	4.13	1 1/2" (x44)	7/8" (x8)

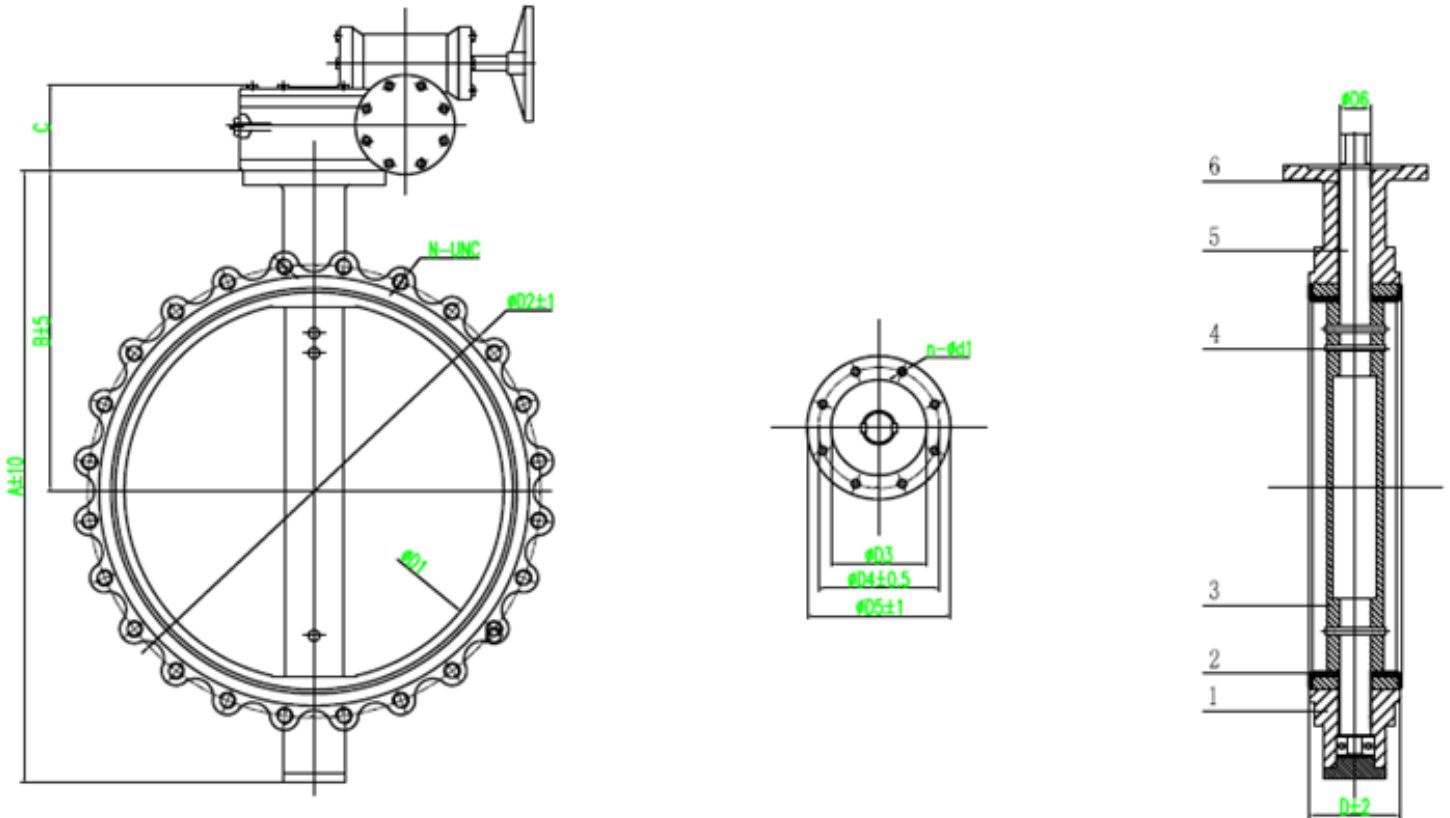

FIGURE 12. 28"- 48" LD141 DRAWING

(IN)	(MM)	A	B	C	D	E	ØF	ØG	ØG2	KEY	ØH	ØH2	L	ØJ	ØK	ØM	LUGS
2	50	3.2	6.375	1.25	1.75	0.394	0.405	0.375	--	--	2.750	--	2.699	4.00	2.09	--	--
2.5	65	3.5	6.860	1.25	1.88	0.394	0.495	0.375	--	--	2.756	--	2.699	4.75	2.54	--	--
3	80	3.7	7.130	1.25	1.88	0.394	0.485	0.375	--	--	2.756	--	2.699	5.13	3.09	--	--
4	100	4.5	7.880	1.25	2.13	0.472	0.621	0.375	--	--	2.756	--	2.699	6.75	4.09	--	--
5	125	5.0	8.360	1.25	2.25	0.551	0.745	0.375	--	--	2.756	--	2.699	7.75	4.85	--	--
6	150	5.5	9.000	1.25	2.25	0.551	0.745	0.375	--	--	2.750	--	2.699	8.03	6.13	--	--
8	200	5.9	10.250	1.75	2.50	0.669	0.870	0.563	0.438	--	4.921	4.015	4.606	10.56	7.89	11.75	2
10	250	6.3	11.500	1.88	2.75	0.866	1.120	0.563	0.438	--	4.921	4.015	4.606	13.06	9.89	14.25	2
12	300	6.8	13.250	1.88	3.13	0.945	1.244	0.563	--	--	4.921	--	4.606	16.00	11.89	17.00	2
14	350	11.0	14.500	1.88	3.13	0.945	1.244	0.563	--	--	4.921	--	Ø5.91*	17.13	13.36	18.75	4

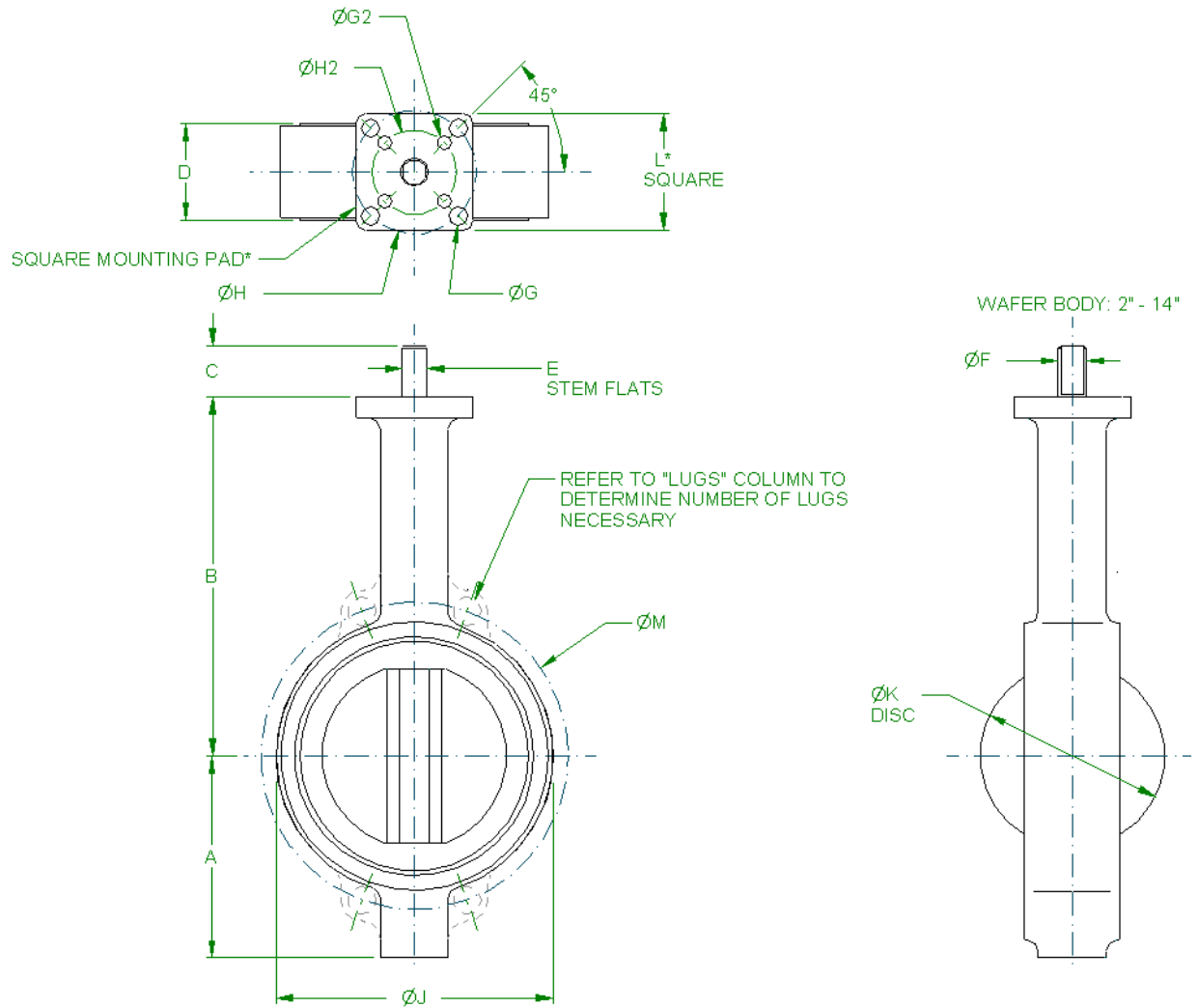

FIGURE 13. 2"- 14" WD141 DRAWING

(IN)	(MM)	A	B	C	D	ØF	ØG	KEY (SQUARE)	ØH	ØL	ØJ	ØK	ØM	LUGS
16	400	12.5	15.750	2.00	3.50	1.313	0.563	0.313	4.921	Ø5.91	20.00	15.38	21.25	4
18	450	13.2	16.630	2.00	4.25	1.500	0.813	0.375	6.496	Ø8.27	21.38	17.38	22.75	4
20	500	14.7	18.880	2.50	5.25	1.625	0.813	0.375	6.496	Ø8.27	23.31	19.38	25.00	4
24	600	18.1	22.130	2.75	6.13	2.000	0.813	0.500	6.496	Ø8.27	27.88	23.38	29.50	4

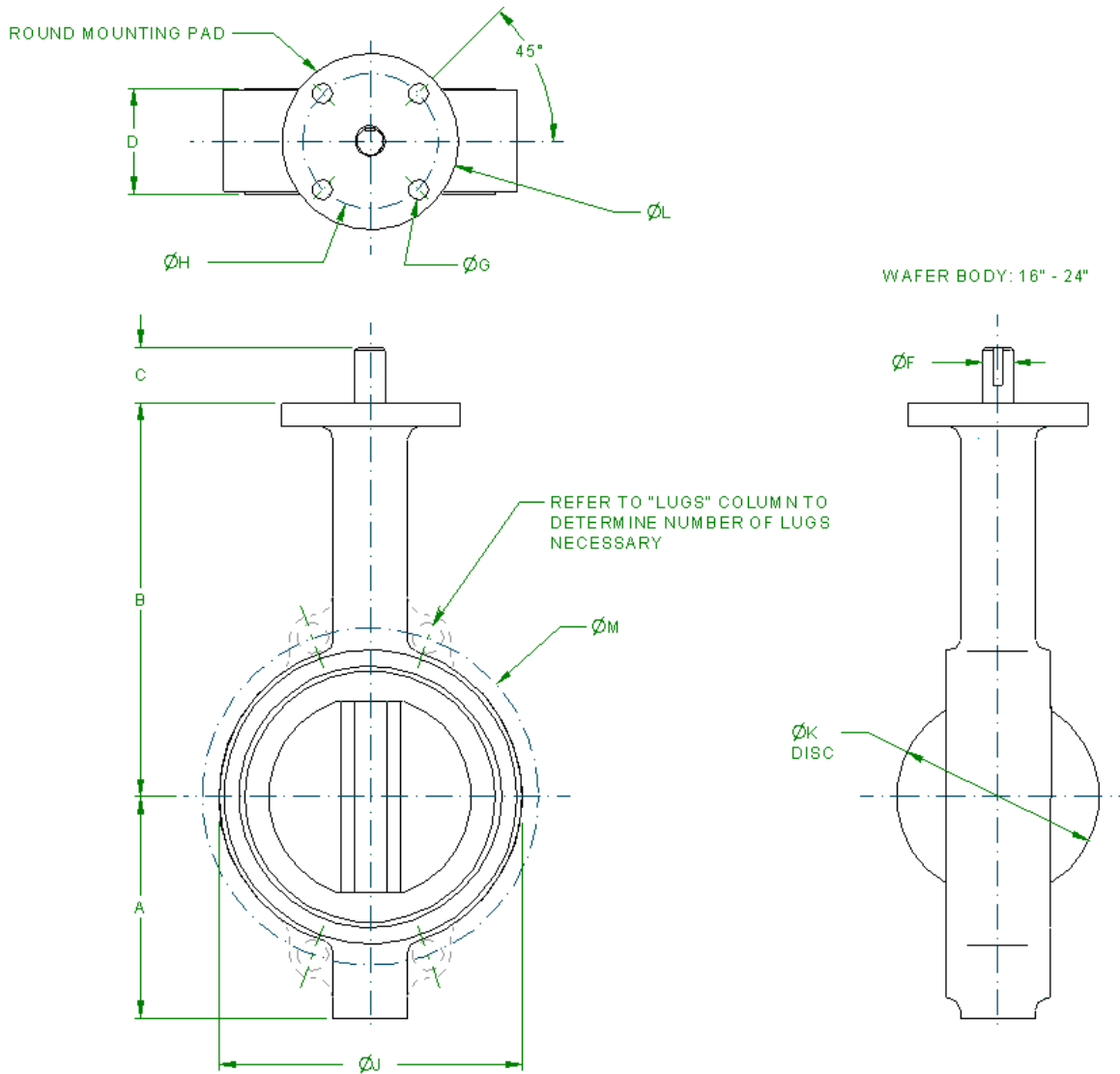

FIGURE 14. 16"- 24" WD141 DRAWING

AMENDMENT REGISTER

Date	ECN	Rev.	Page	Description	Initiator
9/22/2014	M14630	A	ALL	New Release	SAV
6/23/2015	M14879	B	3,7,11	Added NSF 61 to Design Features Updated Figure 1 ID Tag Updated Table 3 Stud & Bolt Specs Updated Figure 7 example nameplate	JLH
7/21/2015	M15219	C	8	Handle Mounting Instructions Added 5. Note	JLH
10/31/2017	M16670	D	7	Added Bolting information and dimensions for large diameter valves	GSF
03/26/2018	M16851	E	2 & 10	Added instructions for infinite position memory stop	GSF